



SFA's best seller!

Similar to the original Saniflo but allows connection of a WC and a wash basin to one macerator pump.



5 m
100 m

SANITOP®

Inlet diameter	40 mm
Discharge pipework	22/28/32 mm
IP rating	IP 44
Electrical power supply	220-240 V / 50-60 Hz
Motor power	400 W
Weight	5.7 kg

Non-return valve included
Active carbon filter included

VERTICAL AND HORIZONTAL
DISCHARGE: ↑ 5 m → 100 m

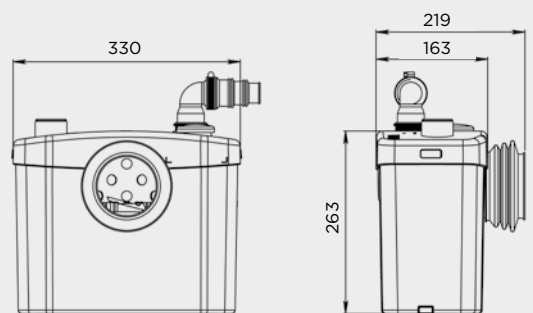
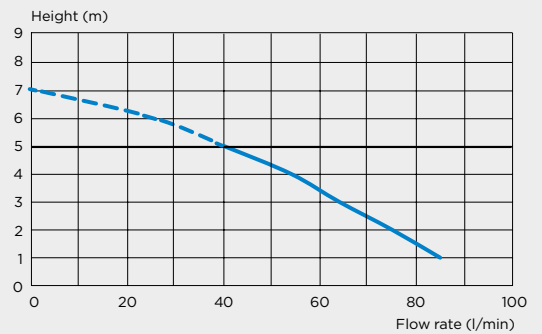

BENEFITS

- One top waste inlet
- Unobtrusive with a quiet motor